

PROCHEM®

Endeavor

CARPET SOIL EXTRACTOR



SAFETY, OPERATION & MAINTENANCE INSTRUCTIONS

MODELS: SX9000 ENDEAVOR
SX9500 ENDEAVOR 500

- **CAUTION – READ THE INSTRUCTION MANUAL BEFORE USING THE APPLIANCE**
- **ORIGINAL INSTRUCTIONS**
- **MANUAL ALSO AVAILABLE ON LINE AT WWW.PROCHEM.CO.UK**



MACHINE DATA

MODEL NO.	
SERIAL NO.	
DATE OF PURCHASE	
DISTRIBUTOR NAME	
DISTRIBUTOR TEL NO.	
MANUFACTURER CONTACT	Prochem Europe Ltd. Oakcroft Road, Chessington, Surrey KT9 1RH, UK Telephone: + 44 (0)20 8974 1515 Fax: + 44 (0)20 8974 1511 Email: sales@prochem.co.uk Website: www.prochem.co.uk

All information and specifications in this manual are current at the date of issue. However, because of Prochem Europe policy of continual product improvement, we reserve the right to make changes at any time without notice. Please note that this manual applies to all models and explains variations including accessories used. Therefore, you may find some explanations for variations and options not installed on your equipment.

CONTENTS

	PAGE NO.
WARRANTY	5
WARNING SECTION	6
IMPORTANT SAFETY INSTRUCTIONS	7
GENERAL DESCRIPTION OF APPLIANCE & IMPORTANT OPERATING INSTRUCTIONS	8
GENERAL OPERATING INSTRUCTIONS	9
UNDERSTANDING YOUR SOIL EXTRACTOR	10
ACCESSORIES & CHEMICALS	11
OPERATING INSTRUCTIONS	12
PRACTICAL CARPET CLEANING	14
GENERAL MAINTENANCE	15
GENERAL FAULT FINDING	17
PARTS DIAGRAMS	18
PARTS LIST	25
PUMP PARTS LIST	28
WAND PARTS LIST	30
HAND TOOL PARTS LIST	31
WIRING DIAGRAMS	33
CE DECLARATION OF CONFORMITY	35



This product is marked according to the **European Directive (2002/96/EC) on Waste Electrical and Electronic Equipment (WEEE)**.

The symbol on this product indicates that this product must not be disposed of with normal household waste. Please protect human health and the environment by disposing of this product responsibly in the correct manner.

For further information regarding the disposal, treatment, recycling and recovery of this product, please contact:

Prochem Europe Sales Department
Telephone: +44 (0)20 8974 1515

Prochem Europe Ltd. EEE Producer Registration Number: WEE / AJ0044SY

European Directive (2011/65/EU) Restriction of use of certain Hazardous Substances in Electrical and Electronic Equipment (RoHS2).

This equipment does not contain more than the maximum permitted levels by weight of the following substances:

Lead (Pb), Mercury (Hg), Cadmium (Cd), Hexavalent Chromium (Cr (VI)), Polybrominated Biphenyls (PBB), Polybrominated Diphenyl Ethers (PBDE)



MACHINE WARRANTY

DATE EFFECTIVE: 1/7/15

As of the above date, this warranty supersedes all previous warranties and forms part of the contract of sale. Prochem Europe Ltd. (hereafter referred to as "Prochem") guarantees this machine to be free from defects in materials and workmanship for the relevant time period as shown below, and from the actual date of purchase by the user. Proof of the purchase date from a Prochem Authorised Distributor will be required for performance of this warranty.

Rotationally moulded polyethylene tanks2 Years
All other parts except maintenance items (see below)1 Year

THIS WARRANTY EXCLUDES NORMAL MAINTENANCE ITEMS, including but not limited to HOSES, FILTERS, O-RINGS, DIAPHRAGMS, VALVES, DRIVE BELTS, GASKETS, CARBON BRUSHES and damage to motors and other components as a result of failure to replace normal maintenance items. THIS LIST IS NOT EXHAUSTIVE.

To obtain performance of this warranty, contact the Prochem Authorised Distributor who supplied the product.

The Prochem Authorised Distributor is responsible as the selling agent for the provision of initial training in the correct use and application of the machine and approved chemicals. The distributor is also responsible for service maintenance and repairs during and after the warranty period and the administration of any warranty claims in conjunction with the Prochem Service Department. Failure of any of these provisions and responsibilities may invalidate the warranty and the authorised status of the distributor.

If Prochem receives notice of any defects during the warranty period, Prochem reserves the right to either repair, or replace components that prove to be defective. Goods must be returned before the warranty is approved. Goods sent out prior to the return of faulty items will be invoiced at current prices, subject to standard payment terms (see Prochem Standard Terms and Conditions of Sale). Replacement parts supplied under warranty will be guaranteed for the remainder of the original machine warranty and **NOT** from the date of installation. Spare parts supplied after expiry of machine warranty may be covered by a manufacturer's warranty, subject to inspection by Prochem Europe Ltd. and at its sole discretion. Normal maintenance items, however, are not covered. Replacement or credit of any returned parts will be at the discretion of the Prochem Service Department. Any subsequent refusal to accept their decision will serve to invalidate this warranty with immediate effect.

PROCHEM AUTHORISED DISTRIBUTORS are responsible for machine and accessories service back up during and after the warranty period. Prochem will furnish parts if the warranty is approved, but **DISTRIBUTORS** will be responsible for fitting, service, labour and related charges including travel, if applicable, and the cost of returning the machine or parts to Prochem. If any chargeable work is undertaken by Prochem for **DISTRIBUTORS** the labour, parts (if applicable) and return carriage will be charged at **FULL LIST PRICE**. If warranty is approved due to genuine manufacturing defect, then labour charges and carriage charges may be waived at Prochem's discretion.

Prochem may send replacement parts to customers supplied by a **DISTRIBUTOR** or directly by Prochem, subject to the same conditions of replacement and payment above. The customer, however, will be responsible for fitting, labour and the carriage costs of returning repaired parts. Alternatively, Prochem will undertake warranty work at Chessington, subject to the same conditions, but the customer will be responsible for all carriage charges.

Any of the following circumstances involving the machine will serve to invalidate this warranty:-

NORMAL WEAR, ACCIDENTS, USE OF THE MACHINE FOR A PURPOSE OTHER THAN THAT FOR WHICH IT WAS INTENDED, INCORRECT MAINTENANCE, THE USE OF CHEMICALS OTHER THAN THOSE SUPPLIED OR APPROVED BY PROCHEM, INCORRECT INSUFFICIENT OR NON-USE OF DEFOAMER, EXPOSURE TO EXTREME TEMPERATURES OR CONDITIONS, INCORRECT INSTALLATION OR REPAIR & UNAUTHORISED INTERVENTION.

Liability is excluded for the following:-

All forms of damage and special damage founded in tort (apart from death and personal injury) and contract law including but not limited to consequential loss, loss of income and losses incurred in reliance of the contract; service, labour or third party charges and the cost of returning the machine or defective parts to Prochem or Prochem's Authorised Distributor.

As against a person dealing as a consumer, this warranty creates specific rights in addition to any statutory rights, which are unaffected. As against a person dealing otherwise than as a consumer, however, this warranty excludes any implied term that the machine will correspond with a description or a product sample.

With the exception of some specific products which are labelled and intended to be used by a consumer, all equipment, machinery, accessories, products, services and advice supplied by Prochem is intended for professional and industrial use only.

Your Prochem unit is designed to give you many years of reliable service. If a problem should arise during or after the warranty period, contact the Prochem Authorised Distributor or the Prochem Service Department, for details of the services available. Only the original purchaser of the new equipment may seek performance of this warranty – these rights cannot be transferred to a third party.

Prochem Europe Ltd.

Oakcroft Road, Chessington, Surrey KT9 1RH, ENGLAND

Telephone: + 44 (0)20 8974 1515 Fax: + 44 (0)20 8974 1511

Machine Warranty Issue 10 1/7/15

WARNING!

- **Warning!**
Machines shall not be used by children. Children should be supervised to ensure that they do not play with the appliance. This machine can be used by people with reduced physical, sensory or mental capabilities or lack of experience and knowledge if they have been given supervision or instruction concerning the use of the machine in a safe way and understand the hazards involved.
- **Caution** this machine is for indoor use only.
- **Caution** this machine shall be stored indoors only.
- **Warning!**
This machine must be disconnected from the mains during cleaning or maintenance, when replacing any parts or converting the machine to another function.
- **Warning!**
Do not allow the power cord to come into contact with the rotating brush.
- **Caution** under no circumstances should the machine be carried by or bumped up a flight of stairs using the handle, always empty the bucket before storage or transporting the machine.

IMPORTANT SAFETY INSTRUCTIONS

**PLEASE READ THE FOLLOWING IMPORTANT SAFETY INSTRUCTIONS (!!)
BEFORE ATTEMPTING TO USE THIS MACHINE. FAILURE TO OBSERVE THE
INSTRUCTIONS MAY RESULT IN PERSONAL INJURY.**

!! CAUTION

Read the instruction manual before using the appliance.

!! SOUND PRESSURE LEVEL

The sound pressure of this machine, when in use, does not exceed 85 dB (A).

!! APPLIANCE SUITABILITY

This appliance is suitable for commercial use, for example, in hotels, schools, hospitals, factories, shops, offices and rental businesses.

!! FOR MAINS POWERED APPLIANCES during cleaning and maintenance – the plug is to be removed from the outlet socket.

!! TRAINING

You must be trained in the operation of this machine before use. Please read this manual carefully and obtain operating instruction from your Prochem Distributor or authorised representative in the correct use of this equipment and suitable chemicals before attempting to clean.

!! REPAIRS

Should any repairs, including supply cord replacement be required, we recommend that the appliance be returned to an authorised dealer.

!! ELECTRICAL CABLE INSPECTION & REPLACEMENT

This machine must be earthed while in use to protect the operator from electric shock. It is equipped with a sealed and approved EC three conductor cable and three-prong 13A plug. If the supply cord is damaged it must be replaced by a special cord or assembly available from the manufacturer or its service agent. During operation a hazard may occur when running the machine over the power supply cord. The power supply cord should be regularly inspected for signs of damage. If the power supply cord is damaged, it must be replaced.

!! RCD CIRCUIT BREAKER

In common with other household and commercial electrical equipment, an 'RCD' circuit breaker plug device is strongly recommended for this type of equipment.

!! EXTENSION CABLES

Avoid using extension cables with this machine. If an extension cable is used it should be of a suitable rating and no longer than 30 metres. Use only three wire CE approved extension cable with CE approved three-prong earthed plugs and three pole receptacles that accept the machine 13 amp plug.

!! DO NOT use a multiple adaptor socket to connect the machine and heating units or other devices to a single extension cable.

!! DO NOT stand the machine in water to operate such as during flood extraction.

SERIOUS INJURY OR DEATH MAY RESULT IF MACHINE IS IMMERSSED IN WATER!

!! DO NOT pull the machine by the power cable or hoses.

!! DO NOT use this machine with or near flammable vapours. These machines can ignite flammable vapours such as fuels, solvents or thinners.

!! DO NOT operate the machine unless it is completely assembled.

!! DO NOT attempt repairs or maintenance unless you are suitably qualified or experienced. Repairs and maintenance should only be performed by qualified personnel and the machine should be tested for electrical safety before re-use.

!! SPRAY LIQUID ejection could be hazardous as a result of its temperature, pressure or chemical content.

!! IF FOAM or liquid comes from the exhaust switch off immediately.

!! ALWAYS disconnect machine from mains supply when left unattended, when emptying the waste container or cleaning the appliance.

!! WHEN CLEANING THE WASTE TANK use a broad spectrum disinfectant cleaning agent to prevent contamination from any infectious material.

GENERAL DESCRIPTION OF APPLIANCE

The Endeavor machines are hot water spray extraction machines that incorporate a solution and vacuum hose assembly and carpet cleaning tool.

The machines have a separate cleaning solution and waste water tank for the collection of dirty water.

The machines can also be fitted with various accessories to convert the machine to an upholstery cleaning unit.

IMPORTANT OPERATING INSTRUCTIONS

PLEASE READ THE FOLLOWING IMPORTANT OPERATING INSTRUCTIONS (!) BEFORE ATTEMPTING TO USE THIS MACHINE. FAILURE TO OBSERVE THE INSTRUCTIONS MAY RESULT IN DAMAGE TO THE EQUIPMENT.

! DO NOT expose the machine to rain or freezing temperatures. Drain solution system and store indoors when not in use.

! DO NOT operate the machine without solution and waste tank filters.

! DO NOT use boiling water or temperature in excess of 76°C.

! DO NOT use chemicals in the machine other than those manufactured or recommended by Prochem Europe.

! DO NOT use the machine for dry vacuuming. The vacuum must only be used for wet extraction in conjunction with the spray system.

! DO NOT run the solution pump and/or heating unit dry. Always switch off and disconnect the machine and/or heating unit electrical supply when re-filling with solution.

! ALWAYS use a clean bucket to fill the solution tank.

! AFTER USE flush solution system and rinse the waste tank with clean water and remove loose fibres from the vacuum filter.

! ALWAYS observe directions and safety precautions on chemical products.

! ALWAYS pre-test carpet or fabric for colour fastness and suitability with ready-to-use cleaning solution before proceeding.

! ALWAYS use defoamer in the waste tank to control foaming from previous shampoo residues in the carpet.

! IF POWDERED CHEMICALS are used, always premix in a separate bucket before adding to solution tank. If not properly dissolved, powdered cleaning solution may result in damage to the solution pump.

! USE ONLY genuine replacement parts for this machine, supplied by an authorised Prochem Distributor.

! DO NOT use this machine for any purpose other than for its intended design function. Any deviation from its proper use or purpose and any consequential damage that may occur is the sole responsibility of the user.

! ALWAYS discharge soiled solution to a sewage drain linked to a sewage treatment facility.

! DO NOT discharge soiled solution into roadside storm drains.

! DO NOT use the drain valve to lift the machine which may result in damage to the drain valve or leakage from the drain valve mounting.

GENERAL OPERATING INSTRUCTIONS

BEFORE OPERATING THE MACHINE

Read the manual carefully and completely before attempting to operate the unit. This manual has important information for the use and safe operation of the machine and should be kept available at all times. This machine will ensure years of satisfactory service if operated and maintained according to recommendations in this manual. If additional help or information is needed, please contact your distributor or Prochem.

Prochem carpet soil extraction machines have been designed with the operator in mind. Provided you read the instructions relating to the care of your machine and follow them carefully and take advantage of the helpful hints and advice that we have passed on, you will achieve excellent cleaning results and very quickly pay for your investment. A detailed operational guide is given in the following sections, however, the following important points must be emphasised.

FAILURE TO OBSERVE THESE INSTRUCTIONS MAY SERIOUSLY AFFECT THE PERFORMANCE OF THE MACHINE AND INVALIDATE THE WARRANTY

- Connection instructions - The 220 - 240V AC models have been fitted with the appropriate EC type sealed power cable and 3 prong 13 amp plug for the UK market. Ensure the machine is connected to a 13 amp socket outlet having the same configuration as the plug. No adapter should be used with this machine. Any modification to the plug type may be dangerous and will void the warranty.
- This equipment is intended for commercial use only.
- The machine was designed for use on carpet and upholstery extraction applications as per instructions and recommendations written in this manual. Any deviation from its proper use or purpose and the consequential damage that may occur is the sole responsibility of the end user.
- Disconnect the power cord from outlet before servicing. Do not leave machine connected to an electrical outlet when unattended.
- Do not immerse or use this machine in standing water. Such use may cause electric shock.
- This equipment is not designed to handle or use combustible/volatile substances such as gasoline or kerosene, in, on, or near the machine. The use of such materials will cause an extreme hazardous condition.
- Use defoamer at all times to prevent damage to the vacuum motor(s).
- Do not use water in excess of 170°F (76°C).
- To prevent seal damage and chemical build-up to the pump system, run clean water through the solution lines after each days use.
- All repairs must be carried out by an authorised Prochem distributor.
- Repairs should only be carried out by a qualified person.
- Do not use replacement parts other than genuine manufacturers parts as specified in the parts list.
- Do not use chemicals in the machine other than those supplied or approved by Prochem Europe limited.
- Do not use the machine as a 'dry' vacuum. Always pre-vacuum carpets thoroughly with a separate 'dry' vacuum cleaner.
- Keep the solution tank and filter clean. Always use a clean bucket to fill the solution tank.
- Clean the waste tank and vacuum filter daily. Do not allow the vacuum shut-off filter to clog and do not restrict the free movement of the ball float (where fitted). Empty recovery tank regularly during use, do not wait for it to fill up and cut the vacuum motor out.
- Clean the drain valve regularly. Lubricate the valve shaft, slide and PVC elbow connection with suitable oil or maintenance spray. Do not drain the waste tank completely until the end of each job, as this will tend to clog the seal with debris and sediment.
- After use, flush through the pump, solution lines and waste tank with at least two gallons of hot water.
- Do not allow the machine, hoses or tools to freeze. Freezing may seriously damage the pump and fittings. Always drain solution and store indoors when not in use. When in transit during freezing weather, insulate and cover machine, wand and hoses. To prevent hose cuffs splitting in cold conditions, immerse them in warm water before use.

UNDERSTANDING YOUR SOIL EXTRACTOR

OVERVIEW

Extraction machines generally consist of two mechanical parts, a solution pump and fan type vacuum motor(s) - both operated by independent electrical switches located on the main housing. The pump forces a cleaning solution under pressure from a housing tank to the face fibre of the carpet via a solution feed hose and carpet wand. The carpet wand has a spray jet system that is compatible with the pressure from the pump and delivers just the right amount of solution to the carpet. The solution has a short amount of time to be forced into the fibres and emulsify the soil particles before it is extracted by the powerful suction of the vacuum motor. **Because both these functions take place at the carpet wand, it will soon be realised that the speed at which the operator moves the wand is an important factor.**

RECOVERY SYSTEM

The recovery tank has a built-in low voltage (12V) electronically controlled float switch system that allows the vacuum motor(s) to be switched off. This operates when the waste water / foam level rises in the tank and contacts the float. The float rises and eventually the electrical contact is made within the system and the power is cut to the vacuum motor(s). The float switch will only be reactivated when the tank is emptied.

It is important to understand that shut-off devices where fitted are there to act as a **precautionary measure**. Care should be taken to **empty the recovery tank frequently and to use a defoamer** if heavy foam build-up occurs due to previous shampoo residue in the carpet. Emptying of the recovery tank is either by way of a positive drain valve or removable bucket. Where fitted, care should be exercised when opening the valve, particularly when the tank is full as the force of dirty water may overshoot the bucket. The drain valve should be cleaned and kept free of soil sediment regularly.

Do not let the recovery tank overflow and cut out the vacuum motor.

At the same time do not completely empty the recovery tank until the job is finished as this may leave abrasive sediment in the drain valve rubbers. A suggested method is to drain 10 litres of dirty water regularly and at the same time refill with clean hot solution **using a separate bucket**. By using this technique, the solution tank is kept topped up and the recovery tank is always below warning level all in one journey.

- **Always ensure that the intake filter bag is cleaned as regularly as possible and whenever waste tank is emptied.**

- **The machine should never be used without the intake filter bag in place. The filter bag performs many vital functions as well as fibre collection. Removing the filter bag may invalidate the warranty.**

When cleaning out the recovery tank, follow these steps -

Place an empty bucket under drain valve and open drain valve slowly. Empty tank and replace bucket leaving drain valve open. Rinse tank with at least 10 litres of hot water, or Prochem deodorising solution. If there is unused solution in solution tank, close drain valve, then switch on the vacuum. With the vacuum hose connected to recovery tank, place the open end of vacuum hose in the solution tank and extract all clean solution into recovery tank. Extract small amounts at a time using the hose cuff on the surface of the cleaning solution to avoid foaming and excessive ingestion into the recovery tank. This will clean the inside of vacuum hose as well as finally rinsing out the recovery tank. Remember to leave the vacuum running for a few minutes after you have extracted, as this will help dry out the hose and avoid dripping hoses. Alternatively use an open ended solution hose fitted with a quick connect to empty the solution tank using the pump.

WARNING - Do not use extraction machines for dry vacuuming

The vacuum motor on your soil extractor is not protected by a dry dust filter. You should only use the vacuum in conjunction with the solution spray. Any pre-dry vacuuming operation should be carried out using a normal dry vacuum machine.

SOLUTION SYSTEM

The quick connectors on each end of the solution hose are connected to the machine and the carpet wand, completing the solution circuit from the solution tank via the pump to the wand head. The female connectors incorporate a pull-back release ring which houses steel ball bearings. These should be lubricated regularly otherwise connection may become difficult. The carpet wand heads are made from stainless steel. Do not attempt to use the carpet wand on hard floor surfaces or concrete, which may result in damage to the wand head.

- **Always check that the filter in the solution tank is in good condition.** Remember that the filter is there to protect the pump from dirt and fibres and it is a lot easier and cheaper to replace the filter than it is the pump!
- **Always use a clean bucket when you replenish your solution tank.** This help will prevent soil and sediment from entering the cleaning solution tank and pump system!

ACCESSORIES & CHEMICALS

ACCESSORIES

HEATER UNIT

A solution heating unit, with separate isolated power supply, is fitted to the rear of the Endeavor machine and linked into the cleaning solution system.

! CAUTION- WHEN USING THE HEATER UNIT ALWAYS USE THE HIGH PRESSURE SOLUTION HOSES SUPPLIED WITH THE MACHINE.

STAINLESS STEEL UPHOLSTERY TOOL

A lightweight stainless steel cleaning tool that, with care, will not give the problems of the softer alloy materials or plastics, the rough edges of which could damage fine fabric. Suitable for use on all wet-cleanable fine fabrics with an ultra-fine spray tip to avoid over-wetting. This tool is essential for upholstery cleaning.

CARPET & STAIR HAND TOOLS

Larger and heavier hand tool designed for extraction cleaning stair carpeting, edges, small rugs and inaccessible areas. Also ideal for rinse extracting stains after treatment with an appropriate **Prochem** spotting agent. **These tools are NOT recommended for upholstery cleaning.**

VACUUM & SOLUTION HOSES (EXTENSION)

Extension hose assemblies may be used provided they conform to the high pressure solution hose requirements of the heater unit and do not exceed the maximum recommended length for the vacuum configuration. The maximum recommended length of hose for dual 6.6" 2-stage and single 8.4" 2-stage vacuums is 30m (100ft).

CHEMICALS

Prochem specialise in manufacturing chemical products for the soft furnishing cleaning industry, including carpets, floor coverings, upholstery fabrics and curtains. This section refers only to the basic **Prochem** chemicals for general on-site carpet cleaning using the hot water extraction method.

S775 EXTRACTION PLUS

A general use carpet cleaning formula containing a high concentration of low foaming detergents, builders and anti-resoiling agents for effective

cleaning of synthetic and natural fibre carpets. S775 has an approximate pH of 9.5 and should be diluted with hot water at 10 ml. per litre (1 to 100).

S709 MULTI PRO

A concentrated pre-spotter and traffic lane cleaner for treating spots, stains and heavily soiled traffic areas prior to extraction cleaning. Dilute with warm water at 1 - 4 to 1 - 8 and apply by sprayer. For best results, brush into pile using **Prochem** carpet pile brush before following up with extraction cleaning process. S709 has a diluted pH of 10.5, therefore always pre-test fibres for colour fastness before use.

B109 FIBRE & FABRIC RINSE

A mild acidic concentrate for use as a cleaning/stabilising rinse to restore correct pH to the fibre. B109 will help to stabilise fugitive dyes and reduce the possibility of 'jute browning' caused by over-wetting or the use of alkaline cleaning solutions. B109 can be used in place of S775 in the extraction machine solution tank, or applied by sprayer after cleaning. Dilute 10 ml. per litre of warm water through your machine. B109 is normally only used when a dye test suggests the possibility of dye bleed or on light coloured carpets when JUTE is part of the construction and may cause BROWNING.

S760 LIQUID DEFOAMER

Always use S760 especially when foam problems from soapy residue left from previous shampoo cleaning are encountered. Mix 20 ml. of S760 with 500ml of cold water and add to vacuum hose and recovery tank. As you drain off to empty the recovered soiled solution, you simply add more S760 as necessary. Remember, it is only necessary to add S760 when extraction cleaning previously shampooed carpets, so always check the recovery tank for foam at the start of each job.

STAIN REMOVERS, SPOTTERS, PROTECTORS & DEODORISERS

Speciality products such as those listed above are available from the **Prochem** range. Refer to the chemical section of the Product Catalogue for more details. Individual Product Safety Data Sheets on all products are available direct from **Prochem** or Authorised **Prochem** Distributors.

OPERATING INSTRUCTIONS

PUTTING INTO SERVICE

Ensure all switches are in the off position.

Pour clean solution into the solution tank using a bucket with pouring lip. Do not overfill the solution tank.

Use only approved correctly diluted chemical (see chemical bottle label for correct dilution rates).

Connect the vacuum hose from the cleaning tool to the vacuum hose inlet on the recovery tank.

Connect the solution hose quick connector from the cleaning tool to the quick connector on the back of the machine. (Pull back outer sleeve on female connector and push fit onto male connector so that the outer sleeve snaps shut).

Make sure the drain valve is closed by pushing the T-handle all the way in.

Add defoamer solution (as per label instructions) to the waste tank.

When moving the machine from place to place use the handle and wheel using the 2 rear wheels and front castor wheels.

Only place the carpet wand or hand tool onto the area to be cleaned when in use.

The machine must be used in an upright condition on a flat and level surface.

OPERATING INSTRUCTIONS

CARPET WAND

Important: Use only Prochem wands and hand tools with the Endeavor. They are designed to deliver and maintain the correct amount of solution and pressure when attached to the Endeavor pump system. Use of other manufacturers wands may cause over-wetting of carpet, damage to the pump system and lack of pressure.

Plug the machine into a suitable electrical outlet.

Turn on the vacuum and solution switches. Slowly pull the wand head towards you with the solution valve trigger engaged. Then make a pass forward and backward with the vacuum only (no spray) over the cleaned area to remove as much soil and solution as possible. Do not over-wet carpet! Make overlapping passes to prevent streaking.

On heavily soiled carpets, we strongly recommend using a pre-spray solution. If the carpet is heavily soiled, squeeze solution valve lever on the forward pass as well as backwards, allowing cleaning solution a few seconds longer to work prior to vacuuming.

When you run out of solution, turn off the pump. Attach the drain elbow on the drain valve. Place a bucket under the drain elbow and pull up the drain valve T-handle. Dirty solution will pour out until the tank is empty. Close the drain valve. Use a clean bucket when you refill the solution tank.

When the job is completed, turn the switches off and disconnect the vacuum and solution hoses from the carpet tool and the machine. Drain the recovery tank through the drain valve as before.

CLEANING UPHOLSTERY

CAUTION – WE STRONGLY RECOMMEND ATTENDING AN UPHOLSTERY CLEANING COURSE BEFORE ATTEMPTING TO CLEAN FABRIC UPHOLSTERY.

General instructions

Cleaning upholstery with success requires a good knowledge of the type of fabric to be worked on. Look for the cleaning instruction label sewn on the underside of the furniture for the recommended method of cleaning the fabric. If it calls for dry cleaning, do not attempt to clean with the wet extraction method. Otherwise, damage to the fabric could occur. Extraction works perfectly on most wet-cleanable fabrics including synthetic (acrylic) velvets.

Before proceeding, test the fabric for colour-fastness. Apply a small amount of ready-to-use cleaning solution on the fabric in an inconspicuous area. Wait for 2 to 3 minutes and blot the area with a white terry cloth towel. If no colour comes off onto the towel, the fabric should be safe to clean. If a little colour comes off, there is some risk of colours running when you clean. It may be possible to stabilise colours by cleaning with B109 Fibre & Fabric Rinse.

Prepare the machine in the same manner as for carpet (see preparing the machine) cleaning except attach the upholstery tool to the vacuum hose. Connect the solution hose. Pour warm water into the solution tank. Add recommended amount of cleaning concentrate into the solution tank. Turn on the vacuum and pump switches.

Clean with the upholstery tool using as little solution as possible. Make overlapping passes to prevent streaking. Go over the area you just cleaned without depressing the lever (vacuum only) and gauge the amount of moisture extracted for dryness. On heavily soiled areas like arm rests, pre-treat with a recommended pre-spray.

STORAGE AND TRANSPORTATION

The machine can be prepared for storage (indoors only), by ensuring the power cord is coiled and secured using the velcro strap provided.

The solution tank and waste tank are empty and clean.

The drain valve fitted to the waste tank is securely closed.

Transporting the machine to another site in a vehicle can be carried out if the previous conditions are met but the machine must be securely stowed.

If the machine is to be lifted into a vehicle, firstly the cables and waste gate elbow must be removed. The machine can then be positioned up to the rear of the vehicle until the rear of the machine is in contact with the vehicle loading area. The machine can then be lifted and pushed rearwards using the handle on the underside of the machine and the incorporated rear slides, until the handle mounted wheels and large rear wheels contact the load bed. The machine can then be stored in this position inside the vehicle **but it must be secured in place**.

Due to the weight of the machine it may require two people to lift it into any vehicle, or carry it upstairs.

Caution, under no circumstances should the machine be bumped up a flight of stairs using the handle, always empty the bucket before storage or transporting the machine.

USE OF PERSONAL PROTECTIVE EQUIPMENT (PPE)

Operation of this machine requires the use of protective latex gloves. Please be aware that the chemicals may require specific PPE to be worn. This can be found on the Material Safety Data Sheet (MSDS) for that particular product.

PRACTICAL CARPET CLEANING

At this stage you will have a reasonable knowledge of your cleaning machine and suitable chemicals to achieve the best results. If you have carpet cleaning background knowledge or you have attended a **Prochem Training Course**, you will also have an understanding of carpet construction, types of fibres and related problems. The following is a summary of the techniques using your **Prochem Soil Extraction Machine**.

Using the cleaning wand

The procedure for using the carpet wand will vary slightly from carpet to carpet depending on profile and soil content. The effect of using a lightweight wand as a scrub wand is to introduce a certain amount of mechanical agitation that undoubtedly helps to clean better by agitation of the pile fibres.

On the majority of normal soiled carpets no pre-spray cleaner will be necessary (except in problem areas) and a normal mix of 10 ml. S775 EXTRACTION PLUS per litre of hot water can be used. **Prochem** can advise you on the various alternative systems and methods that can be applied for varying soil conditions and carpet types. These are all referred to in the **Prochem Training Course Manual** that is supplied with the course.

PREPARATION & FINISHING PROCEDURE

Clear area of all small items and breakables then -

1. Dry vacuum (dust removal) open areas of carpet - before moving furniture.
2. Move all furniture to areas that you have just vacuumed.
3. Dry vacuum remainder of carpet and edges (optional depending on condition).
4. Pre-spray heavily soiled areas and treat spots and stains.
5. Clean carpet using cleaning method as described below and subject to dye bleed test being carried out.
6. Reset pile with carpet pile brush.
7. Replace furniture in original position, placing Prochem waterproof carpet protectors under all legs and feet of furniture.
8. Use Prochem foam blocks under PLINTH furniture to allow airflow.

When using the carpet soil extraction cleaning method, there are certain basic rules of operation to follow in order to achieve the best results and to avoid over-wetting the carpet. The following is an effective wand cleaning technique -

1. Switch on pump and vacuums.
2. Starting at right hand corner, extend wand approximately 18" in front of operator to the base of the skirting board.
3. Operate solution trigger to apply spray cleaning solution whilst simultaneously drawing back the wand toward the operator thus allowing the

vacuum nozzle to extract the emulsified soil and excess moisture.

4. The distance on this movement needs to be no more than 18". Release the solution trigger to stop spray.
5. The wand is then pushed back over the same path giving the vacuum a second chance to retrieve more moisture.
6. DO NOT apply more solution during the vacuum only pass.
7. The wand head is now moved far enough to the left so as just to cover the left-hand edge of the first cleaning pass and the procedure is repeated.
8. Spray and vacuum then on return pass, vacuum only.
9. Carry out a total of 4 spray and vacuum passes overlapping each one by approximately 1".
10. At this point the wand head is passed back over the area cleaned, using the vacuum only to recover excess moisture.
11. When sufficient carpet has been cleaned and vacuumed, the PILE can be reset using a Prochem Pile Brush lightly brushing the pile toward you as you move backwards.

The speed at which the wand head is drawn back on the cleaning stroke is usually governed by the degree of soiling, for example, the slower the cleaning stroke the deeper the penetration of cleaning solution. The same effect, however, can be achieved by several quicker passes and not allowing the cleaning solution to penetrate too far all at once, and at the same time, using the movement of the wand to agitate the cleaning solution which does help to produce a better cleaning result.

The choice of technique is left to you, but it must be pointed out that when using the slow technique, there is a danger of wetting down to the backing of the carpet and thereby risking a shrinkage problem. Certainly, on all light to moderately soiled areas of carpet, the wand movement should be fairly fast to avoid over-wetting and extended drying out. Remember that in the early stages of getting used to your extractor, **it is far better to re-clean a patchily cleaned carpet than to have a bad shrinkage problem on your hands**. You will be surprised how quickly you will master the cleaning techniques.

If you have under-estimated the degree of soiling in a carpet, you can always revert to one of the heavy soil cleaning operations such as pre-spraying with S709 MULTI PRO.

NEVER FORGET - a few extra minutes spent on preparation and pre-treatment can save you hours on a return visit.

GENERAL MAINTENANCE

All Prochem machines are engineered and built to require a minimum of maintenance. But like any machine, it does require some care to keep it in optimum working condition. Careful attention to these maintenance instructions will give you maximum operating performance and will increase the life expectancy of the machine. To ensure a trouble-free machine, we strongly advise the following preventative maintenance.

DAILY MAINTENANCE

The following should be carried out at the end of each carpet cleaning session.

POWER CABLES & PLUGS

Check the condition of the power cables and plugs. Make sure all wires are correctly located and tightly connected. If damaged, the power cable and plug assembly must be replaced.

DO NOT ATTEMPT REPAIR.

Instruction for replacement of power cable with combined plug (all machines)

!! CAUTION - ONLY QUALIFIED MAINTENANCE PERSONNEL SHOULD ATTEMPT THE FOLLOWING REPAIR

Should the power cable require replacement, please follow the instructions below.

1. The replacement cable and plug shall be of the same specification as the original Prochem part number BE4901 (3 core 1.5mm with 13Amp sealed plug unit)
2. Ensure that the power cord assembly is disconnected from electrical supply point.
3. Unscrew black plastic moulding on base of Powercon connector by depressing silver locking tab in the locating hole and unscrewing one turn at a time. The locking tab will need to be depressed each turn until it separates from the main body.
4. Remove the live (brown), neutral (blue) and earth (green/yellow) wires from the Powercon connector terminals. Depending on age of connector, either an electrician's terminal screwdriver or a T8 Torx driver will need to be used.
5. Pass the end of the new power cord assembly through the lower plastic moulding and through the white cable securing clamp, before terminating the new wire ends into their corresponding terminals. Terminals are marked as L (Live), N (Neutral) and E (Earth) on the plus assembly body.
6. Note the Earth symbol may be shown as - 
7. Attach cable clamp to main body of Powercon connector, followed by the lower plastic moulding screwed onto the main body. Tighten until the moulding cannot be tightened any further and then unscrew slightly until silver locking tab can be seen in the locating hole.

SOLUTION TANK

Flush the solution tank and pump through with 10 litres of hot water. Check the **filter** and clean if necessary. If damaged or compressed, unscrew the **filter** and re-shape or replace as necessary. **DO NOT** store hand tools, cables or hoses in the solution tank as this may damage the filter.

RECOVERY TANK

Flush through with clean water and thoroughly clean the inlet **filter bag**. Thoroughly clean and check the operation of the float switch, both mechanically by moving it up and down carefully ensuring free movement and by switching on the vacuum motor(s) and slowly raising the float this should cut off the motors if operating correctly. If fitted, clean the **drain valve** using a small soft brush to clear any debris or sediment from the drain valve seal. Lubricate the drain valve shaft, slide and elbow connection with a suitable oil or maintenance spray. Check the recovery tank **lid seal** to ensure that it is in good condition.

WAND, HAND TOOLS AND HOSES

Inspect the carpet wand and hand tool for sharp edges or damage (if accidentally dropped). Check the **spray jets** for debris, correct alignment and spray pattern. Clean if necessary using **only** a soft bristle brush - **DO NOT use metal or wire**. Rinse the **vacuum hose** with hot water to prevent soil build-up.

Check all nuts and bolts and tighten if necessary

Pay particular attention to the handle, base-plate and wheel axle shaft securing bolts.

Always keep the machine clean inside and out.

WARNING! FREEZING PROTECTION

If your extraction machine is exposed to freezing weather with solution in the components, the solution will **FREEZE** and in most cases **SERIOUSLY DAMAGE** the machine. To avoid damage, consider the following in the winter season. When the machine is not in use, store it in a **heated building**. This is particularly important in the case of the **WAND** and **HAND TOOL**, which are fitted with brass valves. To avoid freezing between jobs, pump out all the cleaning solution from the machine, wand and hand tool and make sure the wand and hand tool are insulated from the vehicle floor (wrap in a blanket or tarpaulin).

WEEKLY MAINTENANCE

At least once a week, inspect the internal components, solution fittings and electrical connections. Check for signs of **fluid leakage** and tighten or replace fittings as necessary. Make sure all **electrical connections** and **cables** are in place.

Solution Lines and Fittings

Flush the machine with a solution of 1 part water with 20 parts B109 Fibre & Fabric Rinse in order to neutralise the alkaline residue left by the cleaning solution.

Quick connect coupler

Spray with WD-40 or equivalent lubricant to prevent coupler from sticking.

Drain Valve

Apply light oil on gate seals. If machine has to be stored, leave the gate valve open.

SOLUTION PUMP

!! CAUTION - ONLY QUALIFIED MAINTENANCE PERSONNEL SHOULD ATTEMPT THE FOLLOWING REPAIRS

A 220 psi diaphragm or 500 psi piston type pump are fitted to the Endeavor dependant on model. They require little maintenance other than to check for pump head leaks.

The 500 psi pump is driven by an induction motor and therefore requires no maintenance and there are no repairs or replacement parts for this motor. The 220 psi pump is a DC type motor and this unit is fitted with carbon brushes in an end bell kit which is a replacement part. These brushes cannot be checked and any reduction in performance should be referred to in the fault-finding guide or your Prochem distributor.

VACUUM MOTOR

!! CAUTION - ONLY QUALIFIED MAINTENANCE PERSONNEL SHOULD ATTEMPT THE FOLLOWING REPAIRS

The vacuum motor is lubricated for life - no additional lubrication is required. The only other maintenance that may be required is changing the motor brushes. **This should only be carried out by an individual with THOROUGH knowledge of electric motors.**

The brushes should be changed before the brush wears to within 3/8" of the brass holder.

With heavy usage we recommend that the brushes be checked every 3 months. The recommended inspection period for normal usage is at least every 6 months. The estimated brush life is approximately 400 to 450 hours, but inspection and replacement should take place at least every 350 hours to prevent the possibility that brush wear may cause damage to the vacuum motor.

On re-assembly, the lead wires must be kept away from the rotating parts and the motor frame. Always ensure that the green earth wire is re-connected to the vacuum motor body to ensure safe operation. To achieve maximum life, the brushes should be seated on the commutator before full voltage is applied. Do this by applying 50% of the rated voltage for thirty minutes. In the event of electrical or mechanical failure, refer to the General Fault Finding Guide page in this manual and contact your Prochem Distributor. Although some service parts are available, we recommend that defective vacuums be replaced.

GENERAL FAULT FINDING GUIDE

CAUTION - Repairs should only be carried out by a QUALIFIED AND FULLY TRAINED PERSON !

NO POWER

With both vacuum and pump switches in the 'on' position, the vacuum and pump will not run.

PROBABLE CAUSES

Defective power cord
Blown plug fuse
House or building circuit breaker tripped
Float switch in raised position
Faulty float switch or wiring

CORRECTIVE ACTION

Replace power cord
Replace fuse
Re-set breaker switch
Check float switch position
Check wiring / replace float switch system

NO VACUUM

With the vacuum switch in the 'on' position, the vacuum will not run.

PROBABLE CAUSES

Vacuum switch defective
Vacuum motor defective
Loose wire connections

CORRECTIVE ACTION

Replace switch
Replace
Check and correct wiring

LOSS OF VACUUM

While the unit is running, there is a loss of suction at the cleaning tool.

PROBABLE CAUSES

Hole in vacuum hose
Disconnected or damaged internal hose
Waste tank lid seal defective
Vacuum hose obstructed
Vacuum filter clogged
Drain valve open (if fitted)
Vacuum motor defective

CORRECTIVE ACTION

Repair or replace hose
Repair replace or reconnect hose
Replace lid seal
Locate and clear obstruction
Remove, clean and replace
Close drain valve
Replace vacuum motor

NO PUMP PRESSURE

With the pump switch in the 'on' position, the pump will not run.

PROBABLE CAUSES

Defective pump switch
Defective pump motor
Loose wire connections

CORRECTIVE ACTION

Replace switch
Replace pump
Check and correct wiring

LOW PUMP PRESSURE

With the pump motor running the spray from the cleaning wand is below normal.

PROBABLE CAUSES

Solution tank filter clogged
Suction leak at pump inlet
Pressure leak at pump outlet
Quick connect defective
Spray tip worn, clogged or incorrectly positioned
Spray tip non-drip valve seized
Clogged spray-tip filters
Pressure regulator incorrectly set or lost prime

CORRECTIVE ACTION

Clean as necessary
Locate leak and repair
Locate leak and repair
Replace quick connect
Replace, clean or re-position
Dismantle and lubricate
Clean or replace spray tip filters
Re-set pressure regulator or re-prime

PARTS DIAGRAMS

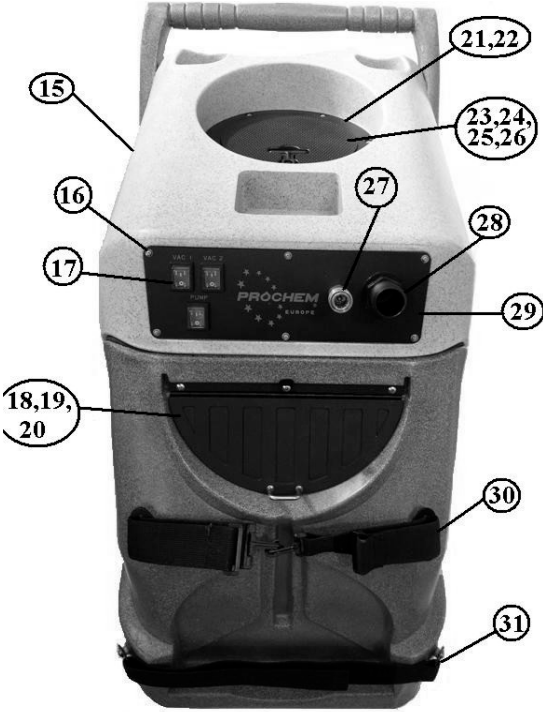

Endeavor Front

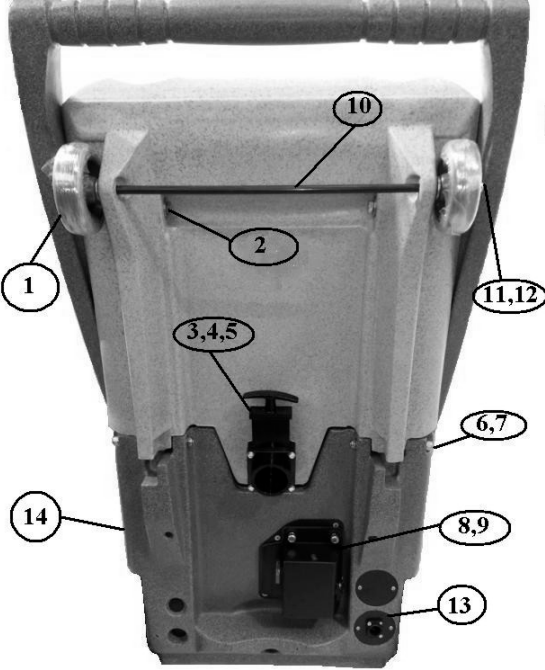

Endeavor Rear



Endeavor Side

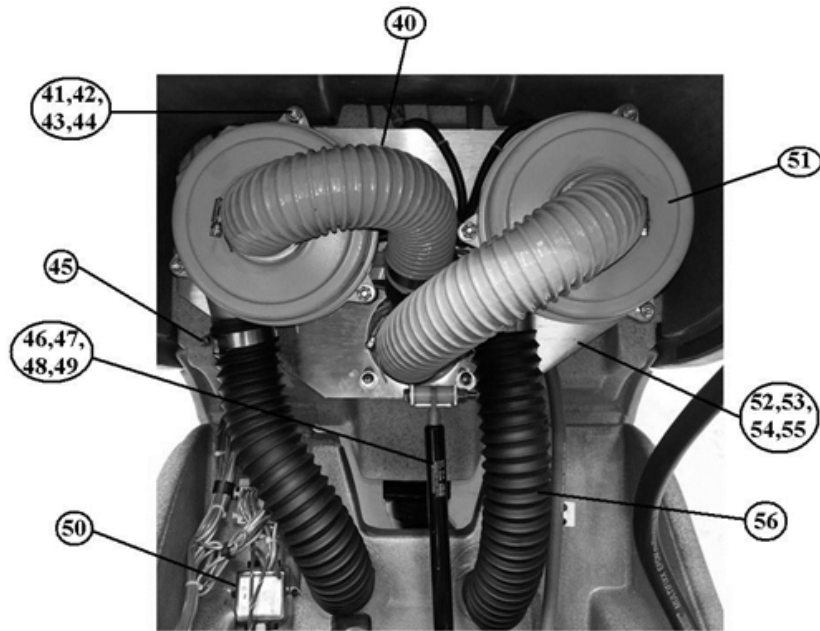

Internal Vacuum Section

Control Panel 500psi

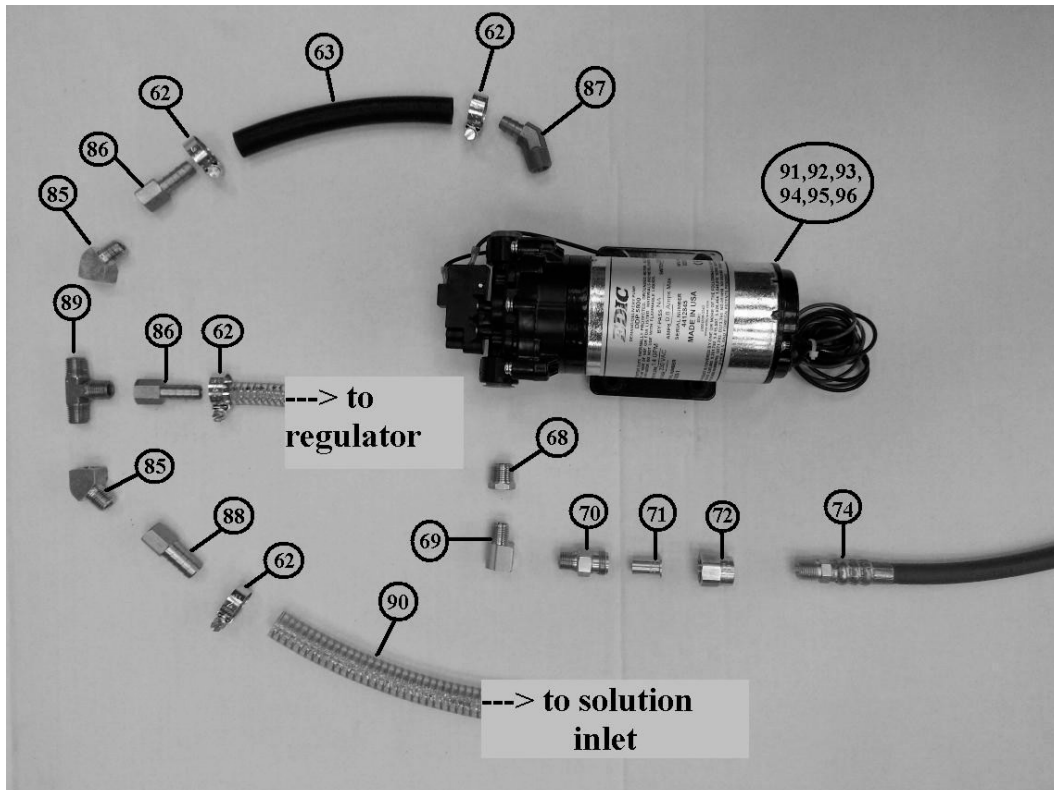
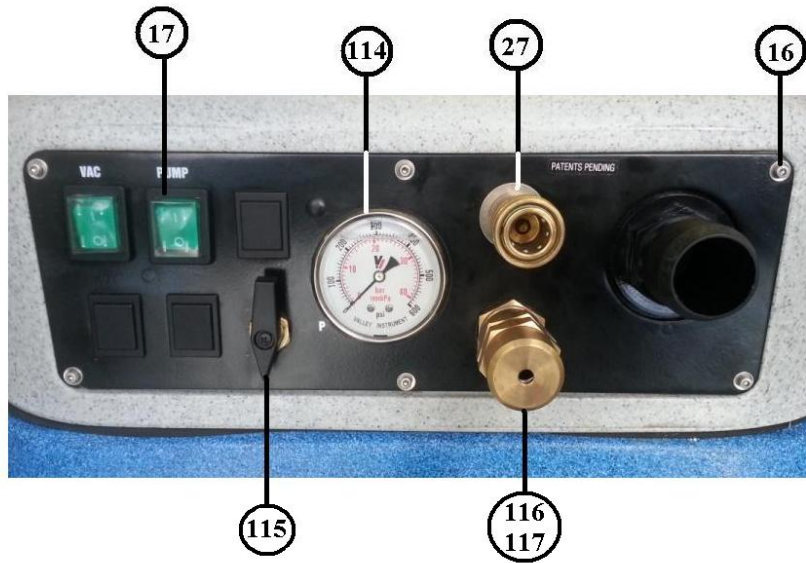

Internal Pump Parts

Solution Inlet
SX9000 220 psi

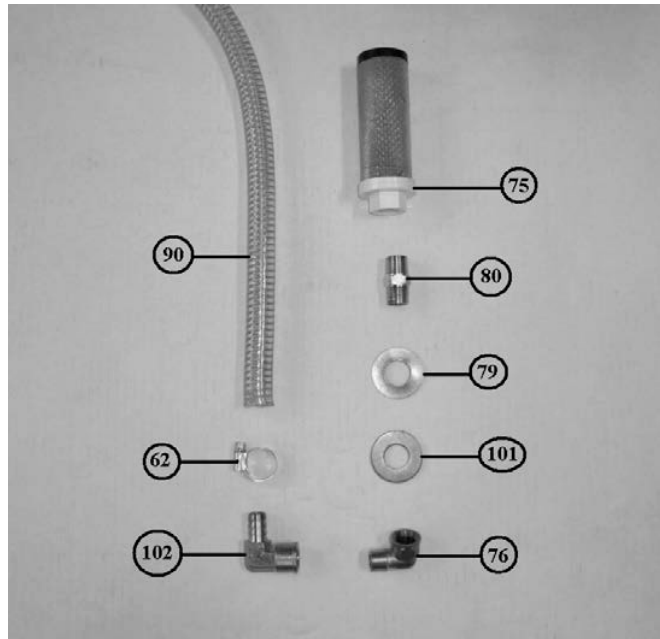

Solution Inlet
& Inlet Return
SX9500 500 psi

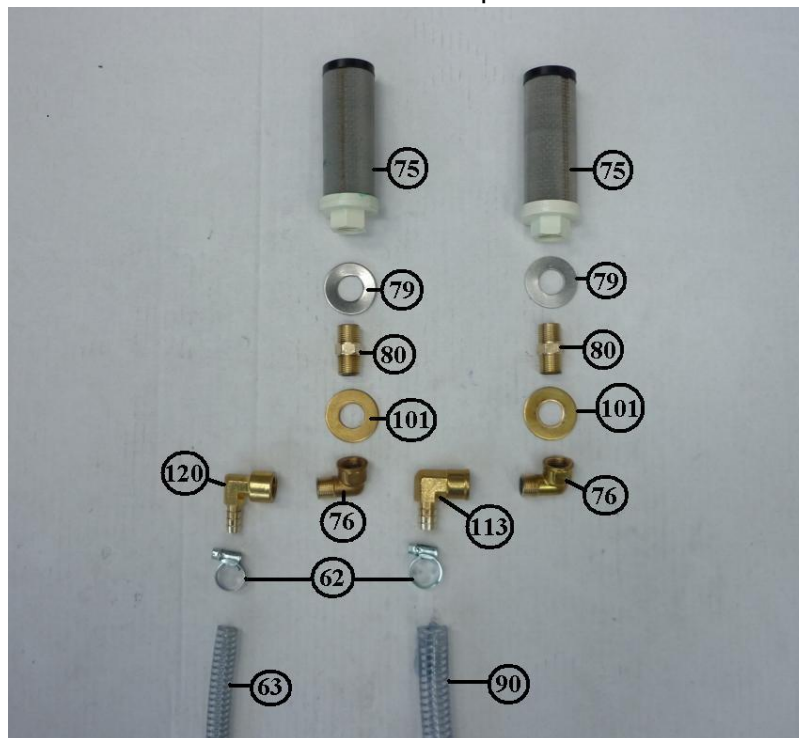

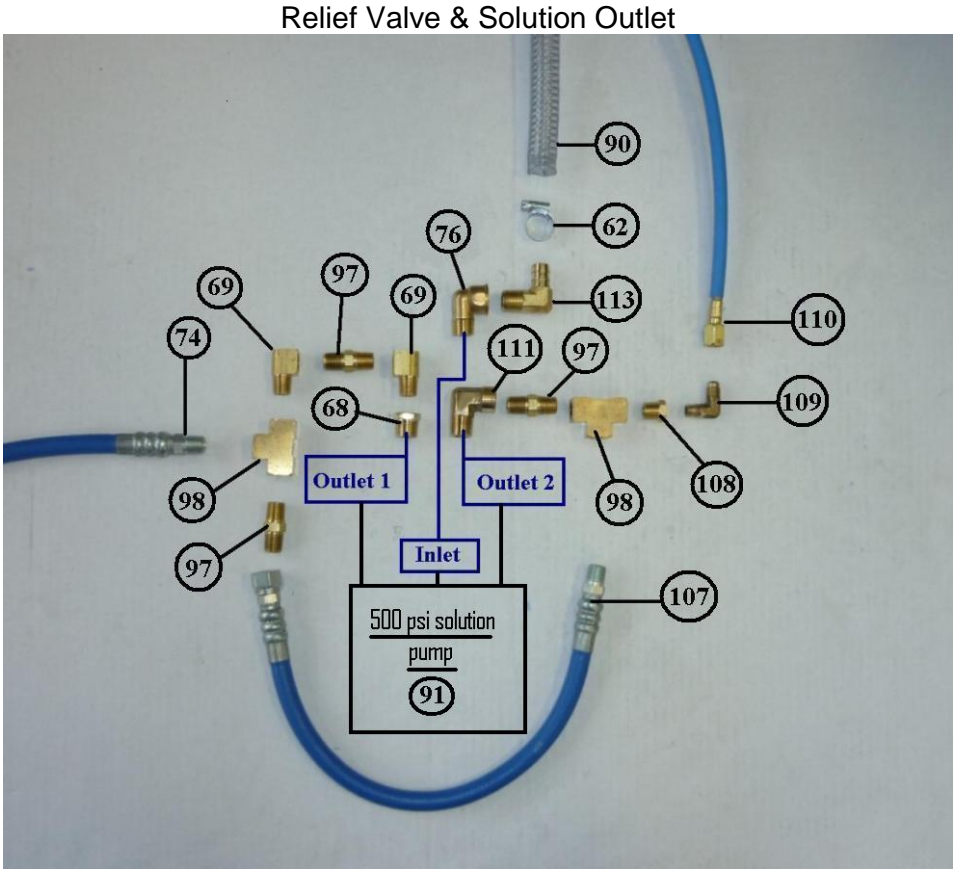
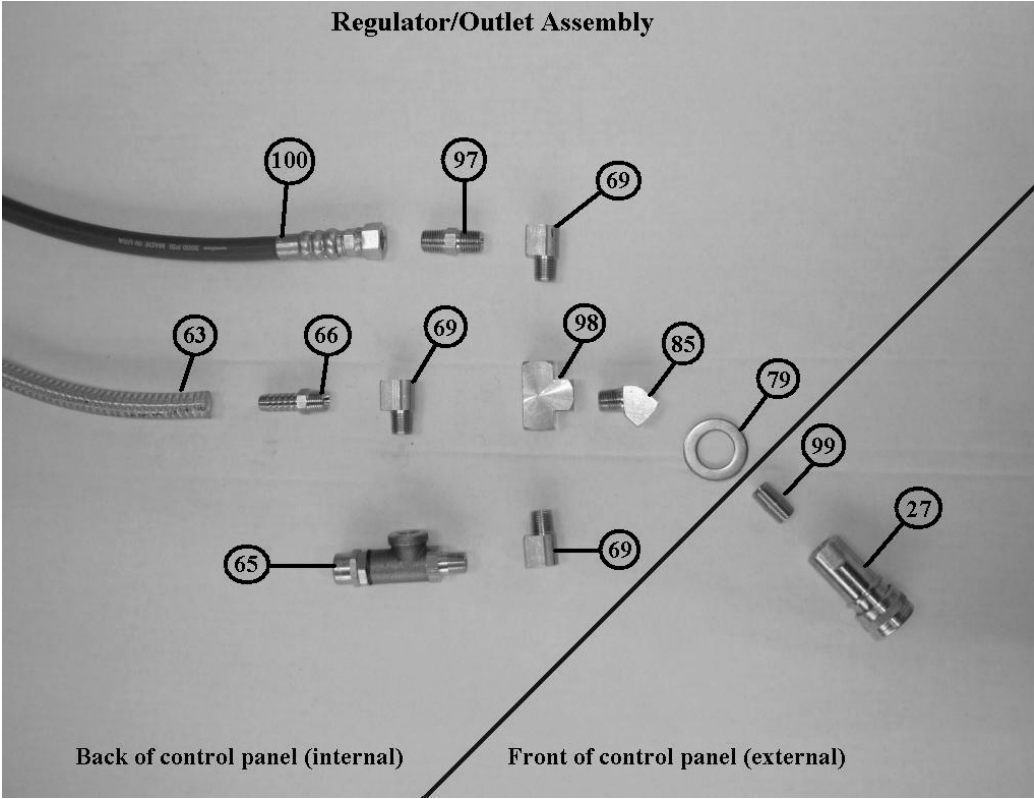

500 psi solution set-up

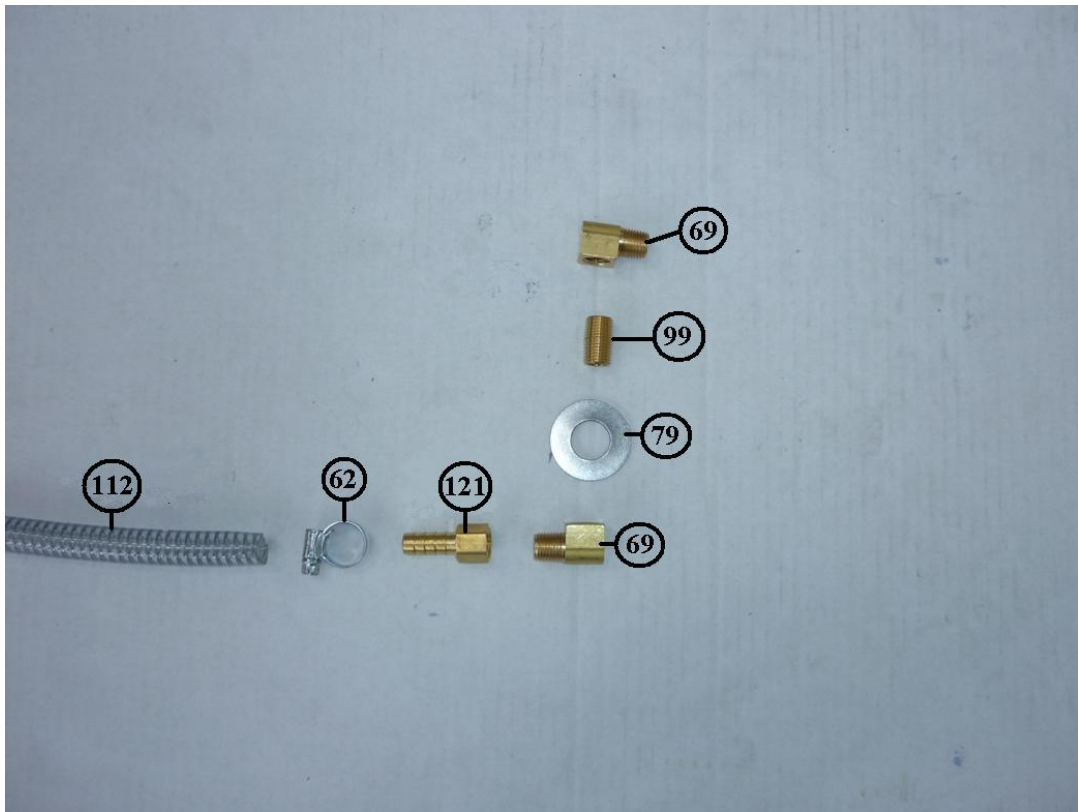
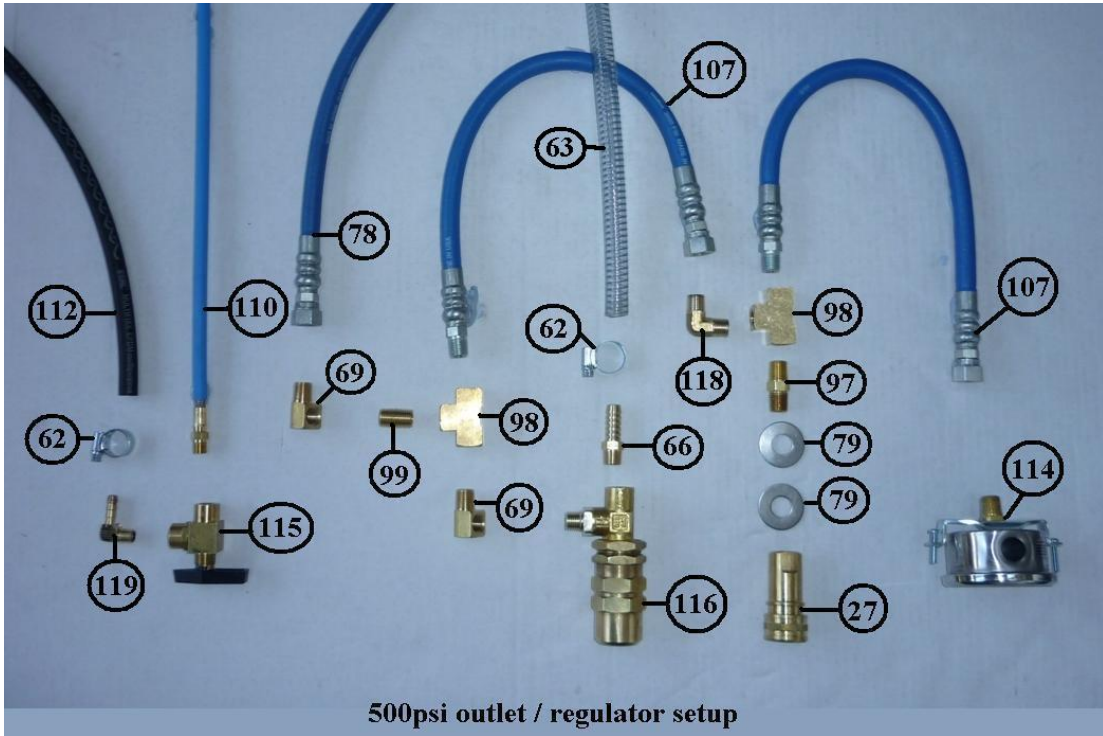

Prime valve parts

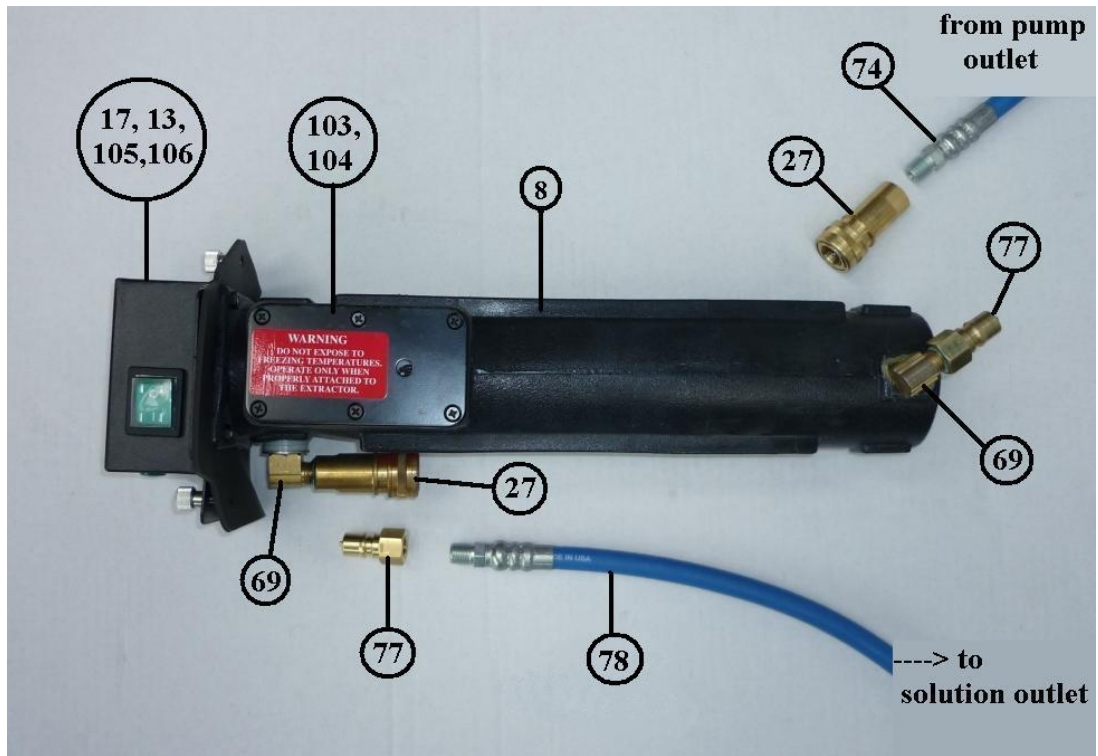

Heat n Run Unit

PARTS LIST

REF	STOCK NO	PART NO	DESCRIPTION	QTY
1		G02531-1	Castor (back, top)	2
2	*		Bolt (retains handle)	2
3	EN00711	K00711	Gate Valve	1
4	E00711-2	K00711-2	Gate Valve Handle	1
5	E00711RK	K00711-1	Seal, Drain Valve EACH	1
6	*		Bolt,Hinge	2
7	*		Nut,Hinge	2
8	AC620	620hrp	Heat and Run (Endeavor)	1
9	*		Blanking Plate (non heat machine)	1
10		D13350	Axle (top wheels)	1
11	E02305-1	C02305-1	Cap Push on	2
12	E11540	C11540	Washer 3/8"	2
13	E13734	B13734	Socket (Machine)	2
13a	BE4901		Power cord set 220-240V, 1.5mm	
13b	E13733	B13733	Connector (Power cord)	
14	*		Base Moulding	1
15	*		Waste Tank Moulding	1
16		C13353	Screw Skt Head	6
17	E02211-1	B02211-1	Rocker Switch Illuminated	3
18		D13355	Solution Tank Lid	1
19	E13525	D13525	Magnet	1
19a	*	D13524	Magnet Catch Bracket	1
20	*		Solution Lid Screws	3
21	*		Waste Tank Aperture Gasket	1
22		C13351	Screw (Aperture Ring)	8
22a		C00278	Locknut (Aperture Ring)	8
23	*		Waste Tank Lid	1
24	E13364	K13364	Float Cage Assy	1
25	E13361	D13361	Waste Inlet Filter Bag	1
26				
27	GU00102	A00102	Female Coupling	2
28	E00913-P	K00741	PIPE ADAPTER 1 1/2"	1
29		D13720	Control Panel	1
30		F13548	Velcro Strap Upper	2
31		F13549	Velcro Strap Lower	2
32	E10510	K10510	Cap Black	2
33	*		Nut Handle Retaining	2
34	*		Solution Tank/Handle Moulding	1
35		G13248	Main Wheel	2
36	*		Hub Cover	2
37	E13387	C13387	Cap Push on 5/8"	2
38		D13356	Axle Main Wheels	1
39	E13218	G13218	Double Castors	2
40	E00618	J00618	2" Wire Hose Grey Per Foot	10ft
41	E11189	C11189	Hex Bolt 1/4 X 20 X 4.5"	6
42	E02473-3	F02473-3	Nylon Spacer	6
43	E00449	E00449	Grommet	6
44	JE00273	C00273	1/4 'Nyloc' Nut	6
45	TT00639	4942166	Stainless Steel Hose Clamp 45-65mm	8

46		G13748	Pneumatic Stabilising Rod	1
46a		G13435	Ball Mount ,Gas Spring	1
46b		G13436	Ball Socket ,10mm	1
46c		D13437	Eyelet , Gas Spring	1
47	*		Bolt	1
48	*		Spacer	2
49	*		Nut	1
50	E90001A	B13600	Filter EMI-RFI 250V	1
	E13723	G13723	Vacuum Motor 2 stage 6.6" 240v	2
51	E13796-1	G13796-1	8.4" vacuum motor (for SX9500)	1
52	n/a	D13682	Vacuum Mounting Plate	1
53	E90007-A	C90007	Screw 10-32 x 0.625,	8
54	JE00233	C00233	1/4" Flat Washer	8
55	JE00254	C00254	1/4" Spring Washer	8
56	E00618	J00618	2" Wire Hose Grey Per Foot	10ft
57	SH5205	94-379-01	Upper Housing, Shurflo	1
58	SH5211	94-391-37	Valve Kit, 150psi	1
59	SH5203	94-385-30	Shurflo Pump Drive	1
60	SH5206	SUK0402	Shurflo Induction Motor Pump 240V	1
61	FJ00054	PN16-10-38	Plastic Elbow 3/8H - 3/8NPT	1
62	RS5217	525-199	Hose Clip 13-20mm	6
63	E00613	RX1017	3/8" Hose, Per ft	4
64	E11243	A11243	Tee 3/8 Nylon	1
	E11314	G11314	Pressure Relief Valve (blue band 180psi) not suitable for 220psi versions	1
65	E11314-3		Pressure Relief Valve (green band 300psi)	1
66	CH00060	GT13/09K	Tailpiece 1/4NPT-3/8H Brass	1
67	E11154	J11154	Solution Hose	1
68	E00168	A00168	Bushing 3/8M X 1/4F	2
69	E00052	A00052	Elbow 1/4F 90' Brass	2
70	DE4906	A011670013	1/4 Nozzle Body,Brass 11/16"	1
71	E00094E	A00094E	Check Valve, No Strainer	1
72	E00097-A	A00097-A	Filter In Line Cap	1
73	E00075	A00075	Tee 1/4" Brass	1
74	E00601HPA	HH---	High Pressure Hose 41"	1
75	E13398	K13398	Solution Inlet Filter	1
76	E11949	A11949	Elbow 3/8" Brass	1
77	GU00104	A00104	Male Coupling	1
78	*		High Pressure Hose 78"	1
79		C12021	Washer 9/16" ID (solution tank)	2
80	E13445	A13445	3/8" Hex Nipple	1
81	FJ5249	CW562	250 psi Pump	1
82	FJ5249-1	V125A40000B	250 psi Rotary Vane Head Assy	1
83	RS5220	789-7889	Cooling Fan 92mm x 92mm	1
84	RS5222	61906961	Cooling Fan (250psi Versions Only)	1
85	E00053	A00053	Elbow 1/4 45' Brass	2
86	E00061	A00061	Female Barb 1/4 - 3/8	2
87	E12023	A12023	Elbow,45 Deg, 3/8 MP x3/8 BARB	1
88		A13376	½" barb x ¼" FPT	1
89		A13372	TEE 1/4" All Male Brass	1
90	FH5201	J11933	½"inch Polywire Pvc Hose	5
	E13639-1		Diaphragm Pump 220psi 230V	1
91	E13803		500psi Pump 230V AC Motor (for SX9500)	1
92	E136391PHK		Pump Head Kit	1
93	E136391PSW		Pressure Switch Kit	1
94	E136391REA		Rear End Bell Brush Kit	1
95	E136391UHA		Upper housing (with pressure switch)	1

96	E136391VHA		Valve kit	1
97	PC800029	8.624-768.0	Hex Nipple 1/4 Brass	2
98	E00161	A00161	1/4" Female Tee	1
99	CH00111		1/4" Close Nipple Brass	1
100	*		Hose, Heater to Outlet/Regulator	1
101	*		Brass washer (solution tank)	1
102	*		Elbow 3/8 x 1/2" Barb	1
103	E5004		Thermostat	1
104	E11258		Thermostat with Breaker	1
105	E02196		Indicator light	1
106	*		Electrical Housing(AC620)	1
107	E00580-15		Solution hose 1/4"m x 1/4"f(swivel) 1.5ft	3
108	E00095-1		Brass Bushing 1/4 x 1/8	
109	PC800040		Elbow 1/8P x 1/4T	1
109a	PC800060		Connector 1/4P x 1/4T (used as an alternative on more recent builds)	1
110	PC805387		Hose 3/16 X 43-1/2 Met Blu	1
111	*		90 Elbow 1/4F x 3/8M	
112	WP4001	RX1017	1/4" solution hose	
113	*		90 Elbow 3/8M x 1/2 barb	
114	E00516-3	G00516-3	Gauge 0-600psi	1
115	*		Prime Valve	1
116	E03523-1		Pressure Regulator	1
117	E14042	G14042	Regulator repair kit	1
118	*		1/4 M x 1/4 M (alternative build uses 1 x E00052 + 1 x CH00111)	1
119	*		1/8m x 1/8barb (alternative build uses 1 x PC800014 + 1 x WL4001)	
120	*		1/4"f x 3/8"barb (alternative build uses 1xE00052 + E00061)	
121	E00067		Female Barb 1/4 - 1/4 (alternative build uses E00061)	1
			ITEMS NOT SHOWN	
	AC2540-HP		25FT HP VACUUM & SOLUTION HOSE ASSEMBLY	1
	PR3005E-H		25FT/7.5M HIGH PRESSURE EXTENSION HOSE ASSY	
	PF00625		Hose Cuff 1 1/2" Grey	2
	E5001		SOLUTION HOSE ASSY HP 25FT	1
	PF00616		Vacuum Hose 1 1/2" per ft.	25
	CF5201		POWER CONVERTER 240V AC TO 12V DC	
	IA5201		FLOAT SWITCH SET	
*			* = Currently awaiting stock code from supplier .Please see future updates on website or contact Prochem service department	

PUMP PARTS LISTS

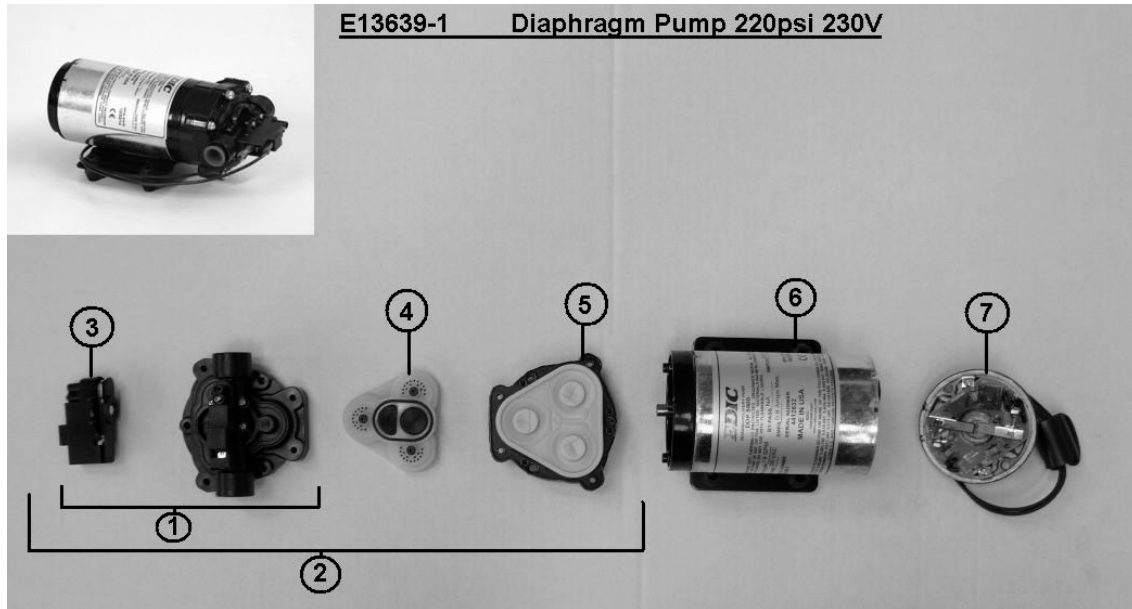

REF	STOCK CODE	PART NO	DESCRIPTION	QTY
1	E136391UHA	E13639-1-UHA	UPPER HOUSING , PRESSURE SWITCH INCLUDED	1
2	E136391PHK	G13639-1-PHK	PUMP HEAD KIT FOR E13639-1	1
3	E136391PSW	G13639-1-PSW	PRESSURE SWITCH KIT FOR E13639-1	1
4	E136391VHA	G13639-1-VHA	VALVE HOUSING ASSEMBLY FOR E13639-1	1
5	E136391LHA	E13639-1-LHA	DIAPHRAGM AND DRIVE BEARING	1
6			230V AC MOTOR	1
7	E136391REA	G13639-1-REA	REAR END BELL ASSEMBLY FOR E13639-1	1

E13803 - 500PSI PUMP 230V AC MOTOR

PROCHEM STOCK CODES

(All parts listed here are held on stock , for non stock part enquiries please contact Prochem service department)

Diagram Reference	Diagram Description	Stock Code	Prochem Stock Description
1	Crankcase	E13872-2	PUMP HEAD W/CAM, 0.75 , 1XP
6	O-ring, Bearing Cover – 7OD	E13869-OB	O-RING BEARING COVER 1XP
8	#2 Cam (0.75gpm.1750rpm)	E13869-075	CAM, 075,1XP
15	O-ring, Head Gasket – 7OD	E13869-OS	O-RING SIDE COVER 1XP
28	Assembly,Plunger/Connecting Rod (Includes: plunger rod , connecting rod & wrist pin)	E13869-PK	ASSY PLUNGER ROD 1XP
29	Kit, Inlet Valve (Includes items 16,17,18,19,20)	E13869-IVK	KIT INLET VALVE 1XP
30	Assembly ,Valve (Includes items:23,24,25,26,27)	E13869-DVK	KIT DISCHARGE VALVE 1XP
31	Kit , Seal and O-ring (includes items 6,10,11,12,15,22)	E13869-SK	KIT SEAL 1XP

500PSI PUMP PARTS LIST

Exploded View

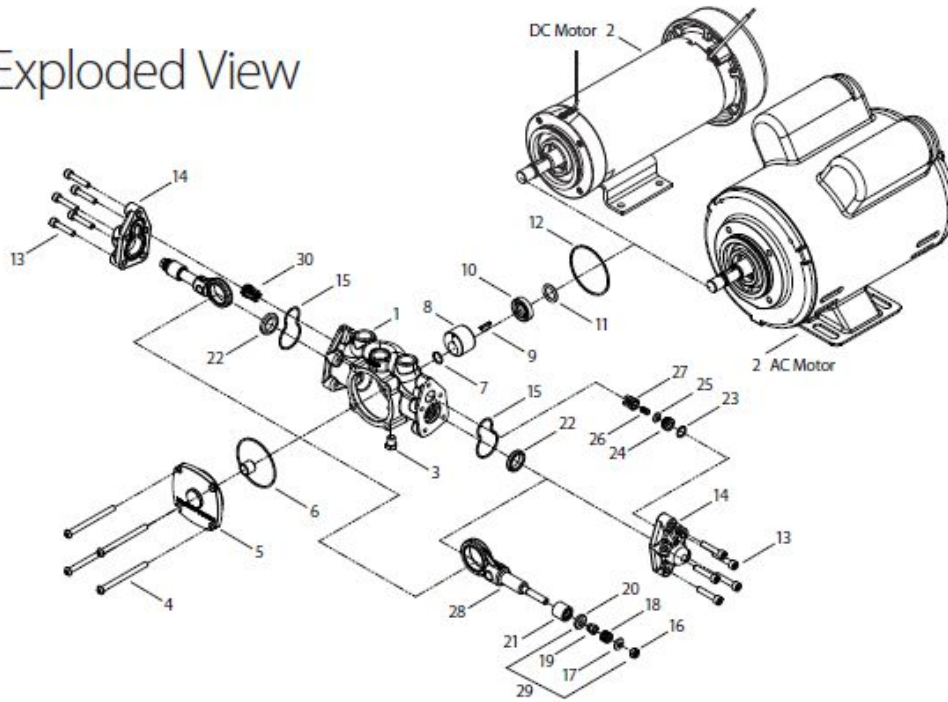

Item No.	Part Number	Material	Description	Qty
1	76801	AL	Crankcase	1
2	8133	-	Motor, 1/3 HP (AC)	1
	8135	-	Motor, 1/2 HP (AC)	1
	8137	-	Motor, 3/4 HP (AC)	1
	8136	-	Motor, 1/3 HP (DC)	1
3	31527	BB	Plug (1/8"- 27NPT)	1
4	76928	STZP	Screw, Button Head (M6 X 7.5)	4
5	76346	AL	Cover, Bearing	1
6	31552	FPM	O-ring, Bearing Cover - 70D	1
7	76701	S	Ring, External Retaining	1
	76520.050	SFSS	#1 Cam (0.50 gpm, 1750 rpm)	1
	76520.075	SFSS	#2 Cam (0.75 gpm, 1750 rpm)	1
	76520.085	SFSS	#3 Cam (0.85 gpm, 1750 rpm)	1
	76520.100	SFSS	#4 Cam (1.00 gpm, 1750 rpm)	1
	76520.125	SFSS	#5 Cam (1.25 gpm, 1750 rpm)	1
	76520.150	SFSS	#6 Cam (1.50 gpm, 1750 rpm)	1
76520.200	SFSS	#7 Cam (2.00 gpm, 1750 rpm)	1	
9	76025	SFSS	Key, Woodruff (#405)	1
10	76133	FPM	Seal, Shaft	1
11	31596	FPM	O-ring, Stinger - 70D	1
12	31552	FPM	O-Ring, Motor Flange	1
13	76909	STZP	Screw, (HSH) (M6 X 30) [01/14]	10
14	76420	AL	Cover, Head	2

Item No.	Part Number	Material	Description	Qty
15	31592	FPM	O-ring, Head Gasket - 70D	2
16	31577	S	Nut (M6)	2
17	31584	S	Washer, Conical (M6)	2
18	44872	S	Spring	2
19	31595	S	Spacer	2
20	76226	NY	Valve, Inlet	2
21	45429	CC	Plunger (M18 X 16)	2
22	43245	SNG	Seal, High Pressure W/Spring	2
23	35426	FPM	O-ring, Valve Seat - 90D	2
24	76576	D	Seat, Discharge Valve [01/14]	2
25	76206	S	Valve, Discharge	2
26	76865	S	Spring, Valve [06/13]	2
27	76069	PVDF	Retainer, Valve	2
28	76555	AL	Assembly, Plunger/Connecting Rod (Includes: plunger rod, connecting rod & wrist, plr)	2
29	76227	NY	Kit, Inlet Valve (Includes: Items 16, 17, 18, 19, 20)	1
30	76218	FPM	Assembly, Valve (Includes: Items 23, 24, 25, 26, 27)	1
31	76219	FPM	Kit, Seal and O-ring (Includes: Items 6, 10, 11, 12, 15, 22)	1
32	76127	-	Kit, Brush Replacement (8136)	1

AL = Aluminum, BB = Brass, CC = Ceramic, D = Acetal, FPM = Fluorocarbon, NY = Nylon, PVDF = Polyvinylidene Fluoride, S = 304 Stainless Steel, SFSS = 17-4 Stainless Steel, SNG = Special Blend (Buna), STZP = Steel/Zinc Plated, (xxxx) = Date of Latest Production Change.

AC1034 WAND PARTS LIST

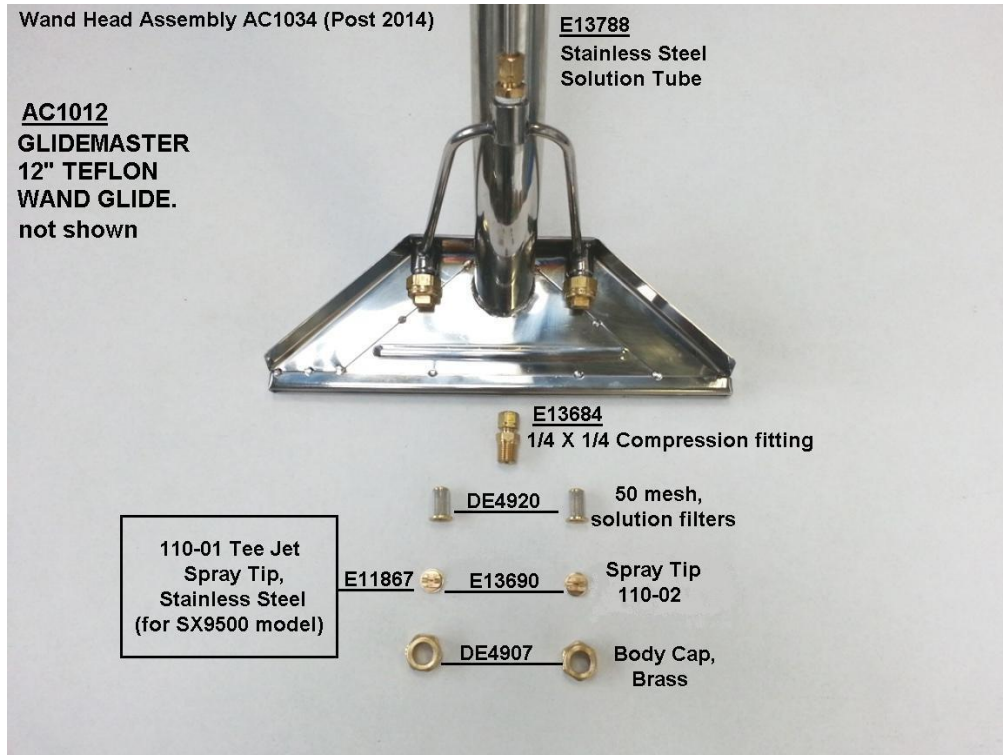

WAND HANDLE PARTS LIST

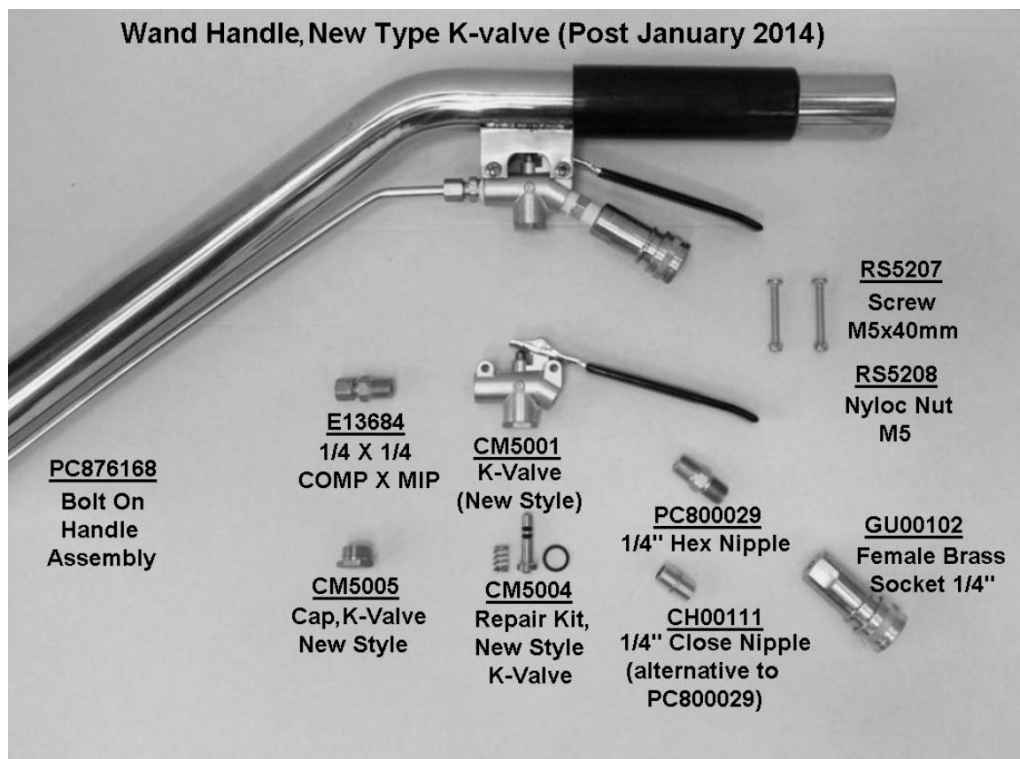

HAND TOOL PARTS LIST

AC1021 Glidemaster Hand Tool Spares
(Post 2014)

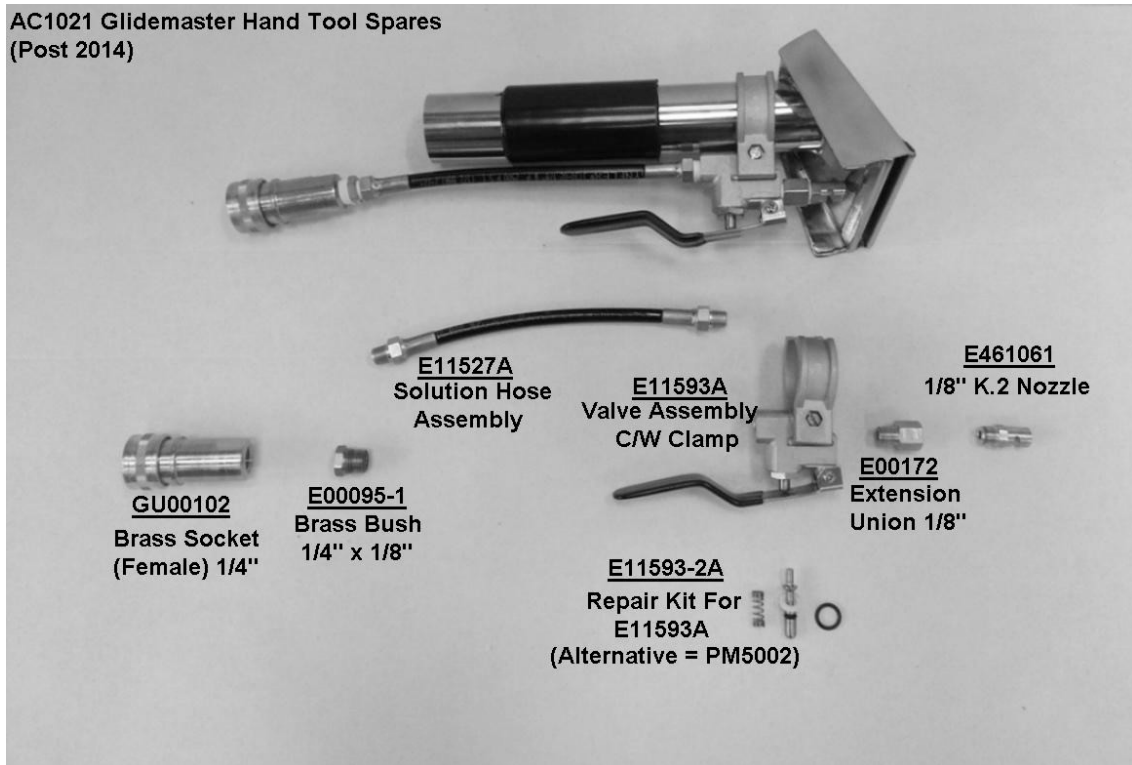

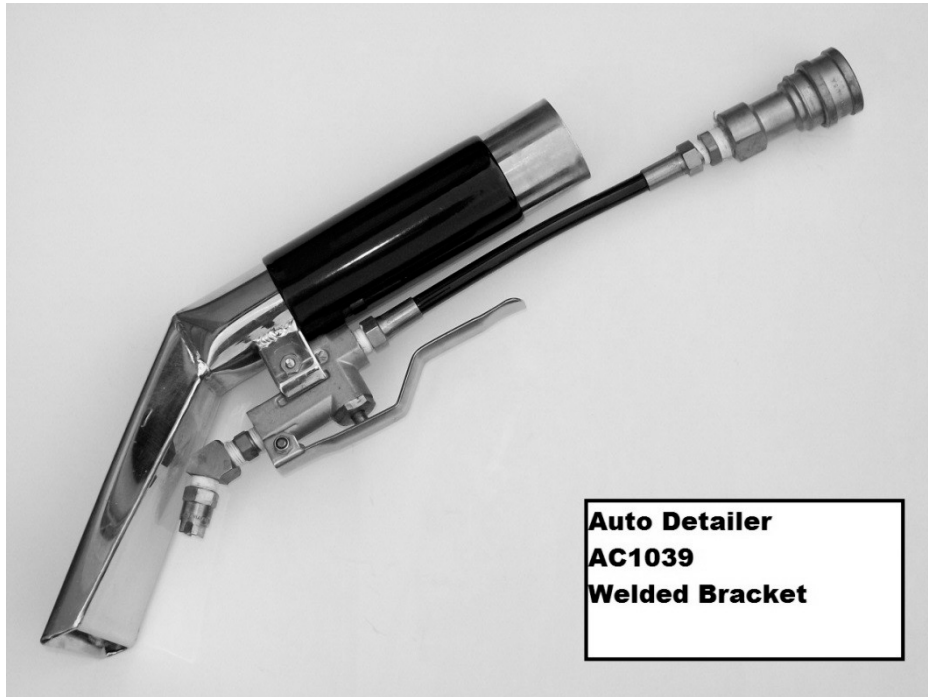

**Auto Detailer
AC1039
Welded Bracket**

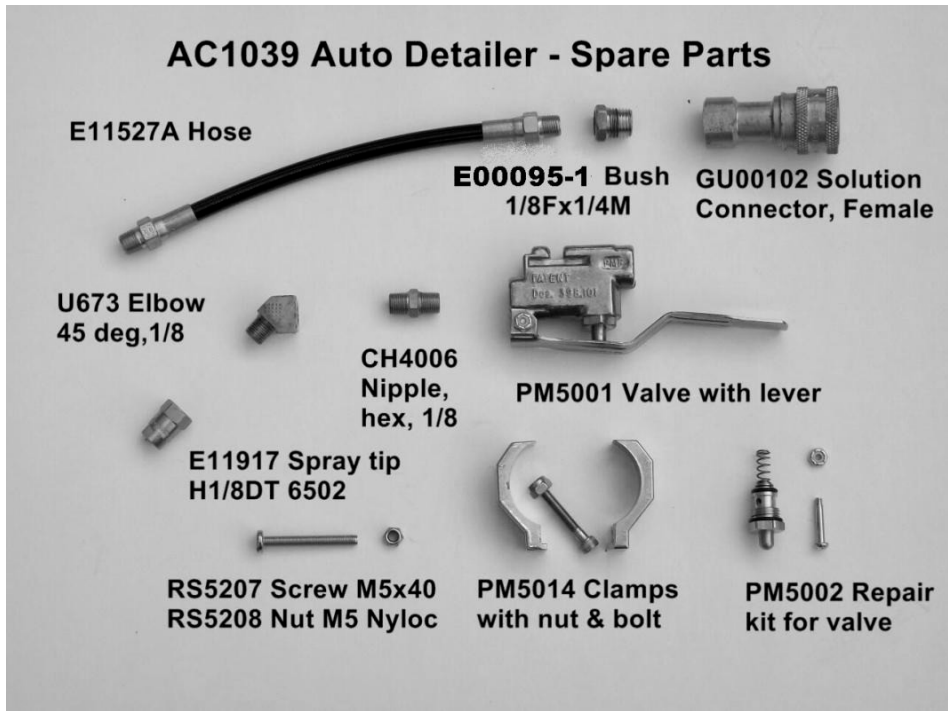

WIRING DIAGRAMS

MODEL SX9000
220 – 240V 50Hz

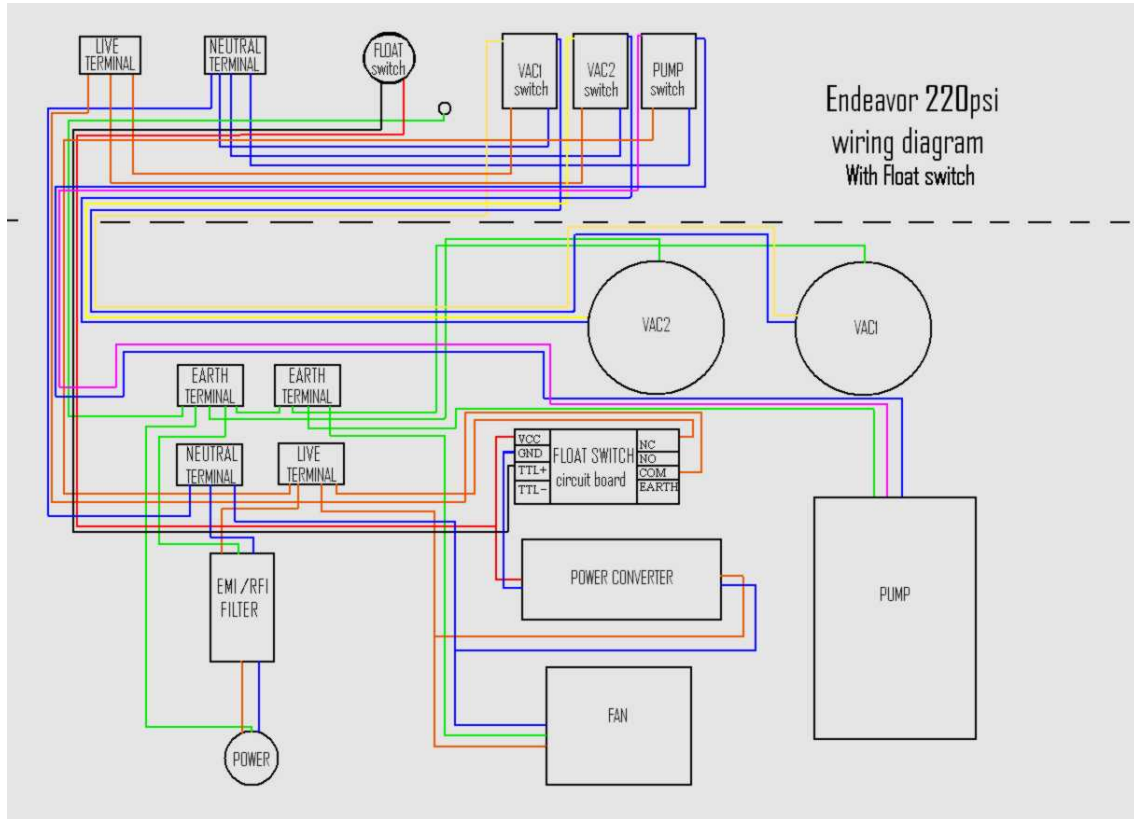

MODEL SX9500
220 – 240V 50Hz

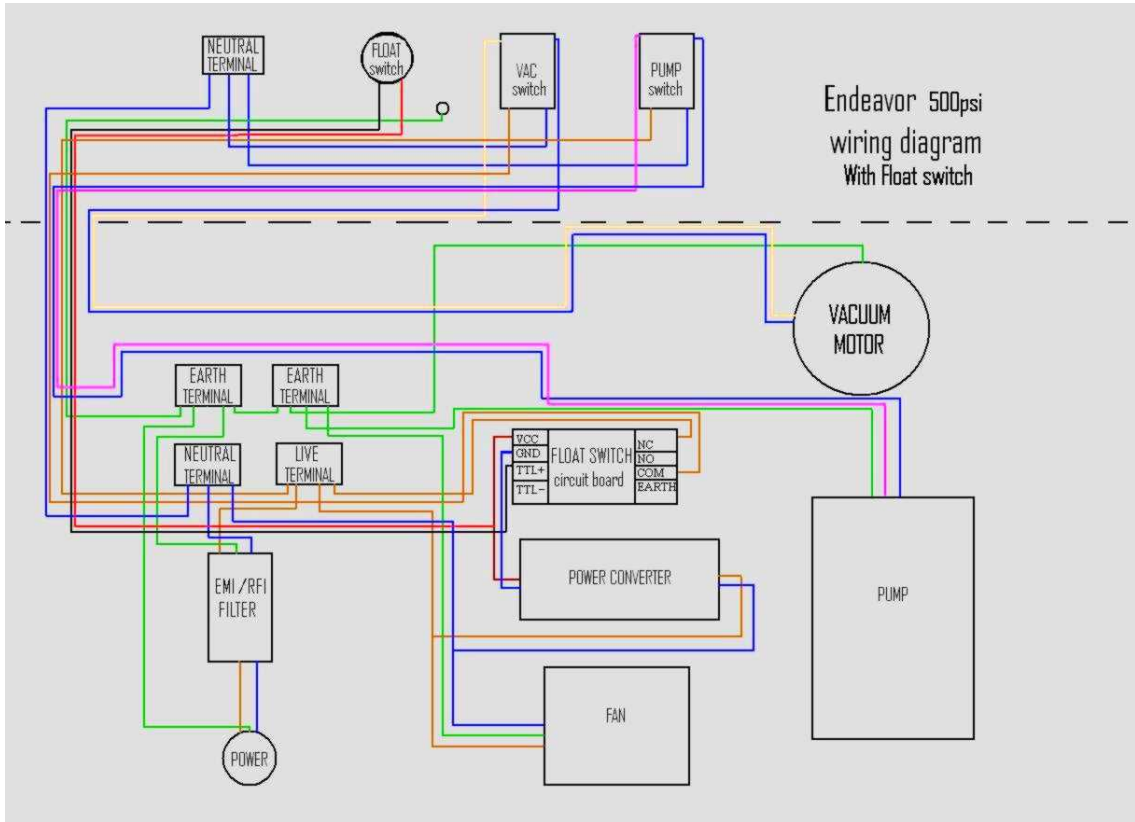

DECLARATION OF CONFORMITY

We:
Prochem Europe Ltd.,
Oakcroft Road,
Chessington,
Surrey, KT9 1RH
UK
(Importer / EC Responsible Person)

E.D.I.C
1753, Blake Avenue,
Los Angeles,
California, 90031-1006
USA
(Manufacturer)

Declare that the product(s):

Type(s): **ENDEAVOR**
Model(s): **SX9000**
Description: **CARPET CLEANING MACHINE 220 - 240V 50 Hz**

Have been manufactured in conformity with the following standards and specifications:

BS EN 60335-1
BS EN 60335-2-68
EN 55014-1
EN 55014-2
BS EN 61000-3-2
BS EN 61000-3-3
BS EN 50366

And comply with the requirements of (as amended):

2006/95/EC **Low Voltage (LVD) Directive**
2004/108/EC **Electromagnetic Compatibility (EMC) Directive**

A Technical file is held by Prochem Europe Ltd.

Certificate of compliance and test reports issued by:

SGS United Kingdom Ltd.
Unit 10, Bowburn South Industrial Estate
Bowburn, Durham DH6 5AD

Signed
(For and on behalf of the Importer / EC Responsible Person)

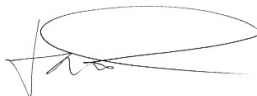

Name: J Hattersley
Position: Equipment Product Manager
Place of Issue: Chessington UK
Date of Issue: 1/6/2013